

# MiMagic 3

## Low Power Applications Processor

### Product Highlights

The MiMagic 3 (NMS7210) Applications Processor provides:

- **High System Performance** 110 MHz 32-bit ARM V4T compliant RISC processor (ARM720T) with two independent bus architecture (32-bit Static Memory bus and 16-bit SDRAM bus) providing separate interfaces for simultaneous access to program store and system memory eliminating shared bandwidth bottleneck. Split bus enables XIP feature, optimizing system performance. Dynamically assignable DMA controller.
- **Very Low System Power Consumption** Low power 0.18  $\mu\text{m}$  1.8 V process. SDRAM interface operates at 1.8 V or 3.3 V; 80 KB of internal SRAM buffer for display refresh without external memory access; frequently used code (e.g. MP3 Software decode) or data (e.g. MPEG-4 decoded intermediate data) can be stored in the SRAM buffer to minimize external memory fetches during program executions. Multiple power down modes including run mode at programmable frequencies, idle and standby. For Standby mode, both CPU and system bus clocks are shut off with LCD display either on or off.
- **Multimedia** High speed DMA-backed Video Port.
- **Wireless connectivity** Support for Bluetooth, IrDA and Baseband through serial (UARTs, USB, SPI) interfaces.
- **Multiple Boot Options** Flash, UART, MultiMediaCard, and serial EPROM. These options are useful in product development, production or for field software upgrade.
- **Low System Cost through High Integration** Supports low-cost NAND Flash. Rich set of on-chip peripherals including color LCD controller, SD Card, MultiMediaCard, USB Host and Function (including USB transceiver), serial I/O, and audio I/O resulting in lower Bill of Materials and very small footprint (11x11x1.0 mm).

### Target Markets

The MiMagic 3 Applications Processor is ideal for mobile personal communication, productivity, and entertainment products such as:

- Smartphones and Mediaphones
- PDAs/Wireless PDAs
- Audio/Video Players
- Handheld Information Appliances

### MiMagic 3 Internal Block Diagram

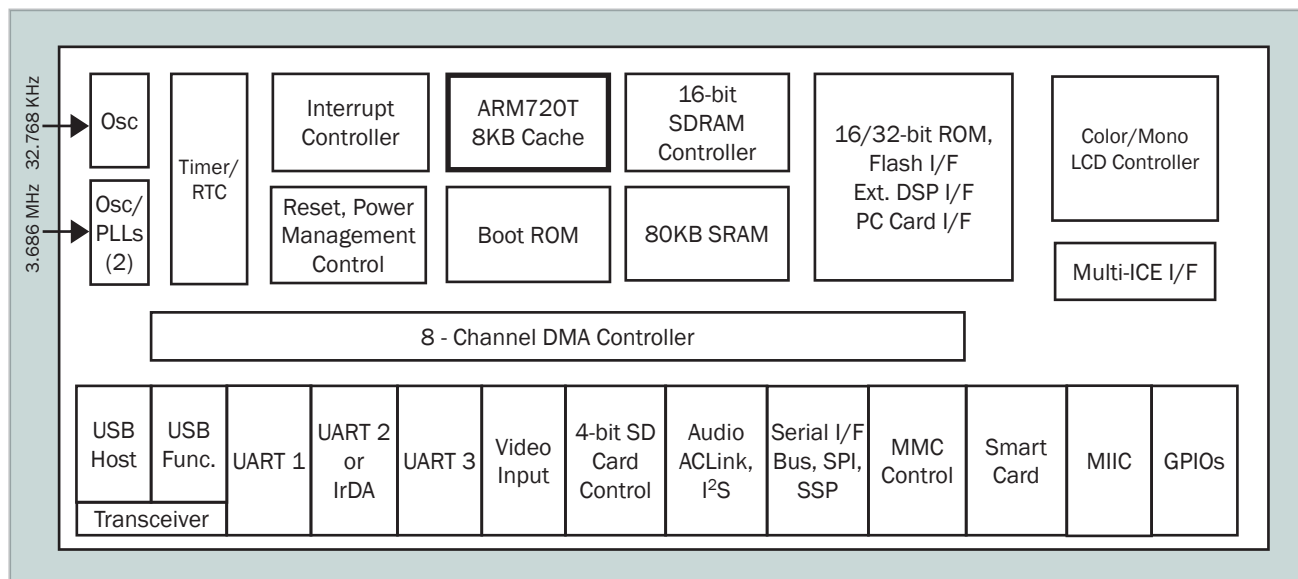

# MiMagic 3 (NMS7210) Specifications

## High Performance, Low Power ARM720T CPU

- 32-bit ARM V4T instruction set with 16-bit extensions (THUMB)
- 8 KB four-way set-associative unified cache
- MMU with 64 entry TLB
- Up to 110 MHz in Asynchronous Mode

## Dual Memory Subsystem

- Dynamic/Static Memory Control
- SDRAM for high performance systems
  - Two physical banks of up to 16 MB each
  - 2 or 4 internal banks per SDRAM device
  - Supports 16 bit wide 1.8-3.3V SDRAM at speeds up to 74 MHz
  - Separate data path for LCD refresh activities
- Static Memory Control
  - 16/32-bit wide data path for SRAM, Flash (NOR and NAND), ROM and External I/O
  - Five memory segments of up to 64 MB each
  - Each segment configurable as 16/32-bits
  - Programmable access time
- PC Card / CompactFlash
  - Interface to PC Card/CompactFlash through NeoMagic NMC1121

## 80 KB On-Chip SRAM

- On-Chip LCD frame buffer: reduces power and memory bandwidth requirements
- On-Chip program/data storage to speed up program execution

## Display Subsystem

- Color/Mono LCD Controller
  - 640 x 480 STN/DSTN or TFT
  - Supports up to 16 bpp (64 k colors)

## Video Support

- High speed data port, 16 MBytes/s with DMA (video port)

## SD Card Controller (24 MHz)

- MMC Compatible

## MMC Card Controller

## Smart Card Interface

## Audio Interface with DMA

- AC97 Interface (V 2.1)
  - Stereo Audio support
  - Variable Sample rate, 16-bit
  - Modem support
- I<sup>2</sup>S Serial Interface
  - Stereo Audio support, 16-bit

## USB Host (USB 1.1)

- Host interface at 1.5 and 12 Mbps
- On-chip transceiver option
- DMA support

## USB Function (USB 1.1)

- Function interface 12 Mbps
- Control, bulk in/out and interrupt transfer modes
- On-chip transceiver option
- DMA support

## Serial Communication Subsystem

- 3 DMA backed UARTs, up to 460 Kbps
  - One with modem control signals
  - Support for Bluetooth rates
- IrDA 115 Kbps, 1.152 Mbps and 4 Mbps

## Serial Interface Bus with DMA

- Philips UCB1200 Interface (telephone codec, touchscreen interface, audio codec)

## Synchronous Serial Ports with DMA

- SPI/Microwire interface with Master/Slave modes, runs up to 9.2 MHz

## Power Management Control

- Run/Idle/Standby Modes
- Software controlled state transitions
- Supports low power SDRAM chips (1.8 V Core/I/O)
- Built-in 80 KB low power SRAM for LCD frame buffer to reduce power consumption
- Dynamic Frequency Switching
  - 18/ 36/ 74 MHz in synchronous CPU mode and up to 110 MHz Async. mode

## System Control

- Two 16 bit timer/counters
- Interrupts
  - 3 external IRQ lines
  - 1 external FIQ lines
- Programmable buzzer output
- 32-bit real time clock (RTC)
- Up to 77 GPIOs
- 8 DMA Channels
- Tri-State Outputs and I/O allow high impedance test mode

## On-Chip Debug and ICE support

- JTAG for MultiICE interface

## 1 KB On-chip Boot ROM

- Boot through MultiMediaCard, UART or MIIC
- Sequence programmable by bootstrap options

## Small Package

- FlexBGA package 280-pin 0.8 mm ball pitch
  - Body size 16 x 16 mm, 1.2 mm high
- TABGA package 280-pin 0.5 mm ball pitch
  - Body size 11 x 11 mm, 1.0 mm high

## Operating Range

- 1.8V  $\pm$  5% core; 3.3V  $\pm$  10% I/O
- Commercial/Industrial Temperature Support

## Estimated Typical Power Consumption

- Run : 90 mW at 74 MHz, 1.8V
- Run : 120 mW at 110 MHz, 1.8V, CPU Async Mode
- Idle : 35 mW

## MiMagic 3 Development Systems

The MiMagic 3 Development System is available to evaluate MiMagic 3 Applications Processor and for rapid software development. It provides time-to-market advantage and lower development costs. The MiMagic 3 Development System provides full access to all of the major features and interfaces of the MiMagic 3 Applications Processor. It includes 32 MB SDRAM, up to 32 MB Flash, debug UARTs, Ethernet port, MultiMediaCard / SD Card socket, PC Card socket, USB Host, USB Function, AC97 Stereo module, and LCD panels, among others.

The Development System software includes APIs, sample codes, and comes with a choice of operating systems – Microsoft Windows CE, Symbian and Linux. It comes with full documentation including MiMagic 3 user's manuals and application notes. The development toolkit such as compilers, assemblers, linkers, and debuggers is available from ARM Ltd.

In addition, NeoMagic makes available a PDA reference design based on MiMagic 3 Applications Processor that combines a form-factor plug-in board with a debug board. The form-factor board implements 16 MB Flash, 32 MB SDRAM, SD Card, and SIM Card. The debug board contains complete debug facilities including logic analyzer probes, Ethernet, debug UART, and LEDs, etc.

## Build Handheld Systems Using MiMagic 3

MiMagic 3 Applications Processor is purpose-built to deliver superior user experience in multimedia handheld systems such as Smartphones & Mediaphones, PDAs & wireless PDAs, and audio/video players with best-in-class battery life. Numerous on-chip peripherals reduce component count and board space. Since it is based on ARM's open architecture, many tool chain and third-party support are available to reduce time-to-market.

The following figure shows an application example of Smartphone/Mediaphone using MiMagic 3.

## Application Example of Smartphone/ Mediaphone using MiMagic 3

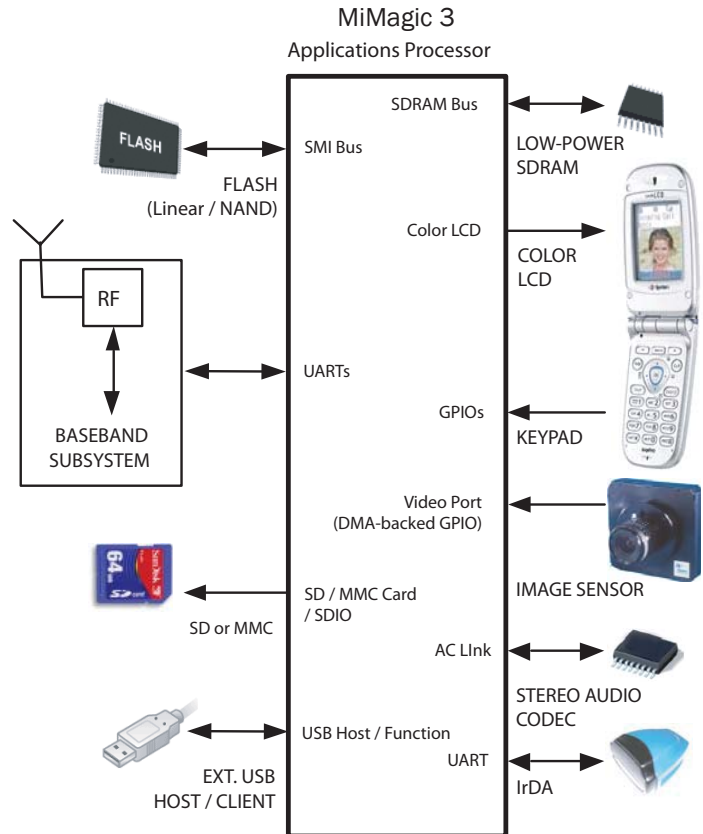

## Ordering Information

NMS7210A-TB280C	MiMagic 3 Applications Processor, Tape Array BGA, 11x11x1.0mm, 0.5mm pitch, commercial grade
NMS7210A-TB280I	MiMagic 3 Applications Processor, Tape Array BGA, 11x11x1.0mm, 0.5mm pitch, industrial grade
NMS7210A-FB280C	MiMagic 3 Applications Processor, Flex BGA, 16x16x1.2mm, 0.8mm pitch, commercial grade
NMS7210A-FB280I	MiMagic 3 Applications Processor, Flex BGA, 16x16x1.2mm, 0.8mm pitch, industrial grade

## NEOMAGIC

NeoMagic Corporation  
3250 Jay Street  
Santa Clara, CA 95054  
Tel: 408.988.7020  
Fax: 408.988.7036